



AIRCRAFT OWNERS AND PILOTS ASSOCIATION



Airplanes!

If you've ever wondered...

- *What are the main parts of an airplane?*
- *What's a fuselage?*
- *What makes an airplane fly?*
- *How do aircraft wings work?*
- *How is a plane controlled?*
- *What is the instrument panel?*



...then this guide is for you!

Here you'll find answers to these questions, experiments to show you how aircraft wings work, and puzzles.

If you want to learn more about aviation, check out the resource list inside, stop by your local library, or check out the Internet.

Have fun!

Provided by: AOPA • 421 Aviation Way • Frederick, MD 21701-4798

www.aopa.org

The Main Parts of an Airplane

1. Propeller
2. Landing Gear
3. Wing Strut
4. Wing
5. Right Wing Aileron
6. Right Wing Flap
7. Fuselage
8. Horizontal Stabilizer
9. Fin and Dorsal
10. Rudder
11. Elevator
12. Left Wing Flap
13. Left Wing Aileron
14. Door
15. Seat
16. Windshield
17. Engine Cowl

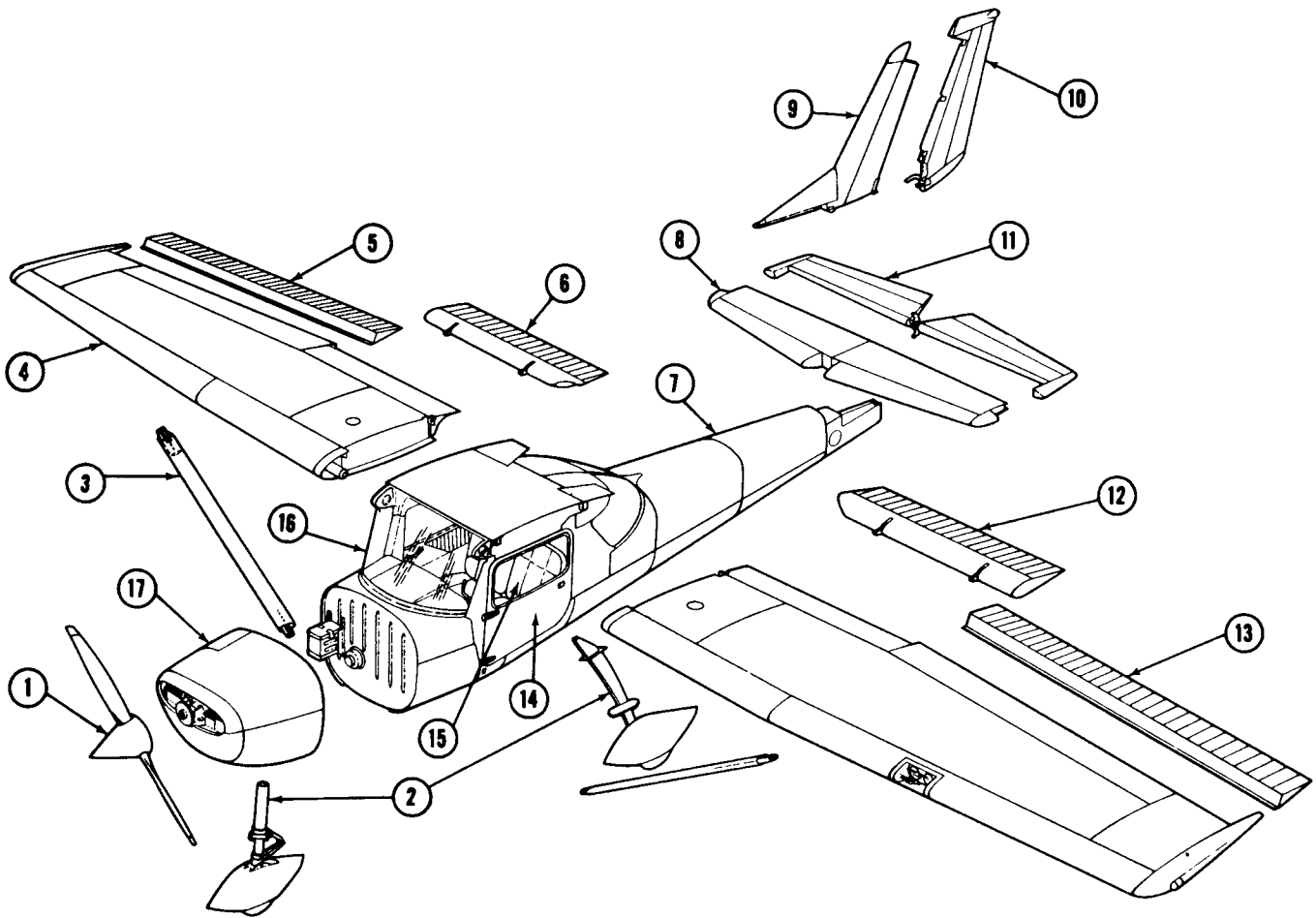

The Main Parts of an Airplane – Definitions

Airplane – An airplane is a vehicle heavier than air, powered by an engine, which travels through the air via the forces of lift and thrust.

Fuselage – The fuselage is the central body portion of an airplane, designed to accommodate the pilot/crew and the passengers and/or cargo.

Cockpit – In general aviation airplanes (all except those operated by airlines and the military) the cockpit is usually the space in the fuselage for the pilot and passengers; in some aircraft it is just the pilot's compartment.

Propeller – A propeller is a rotating blade on the front of the airplane. The engine turns the propeller, which pulls the airplane through the air.

Wings – Wings are the parts of airplanes that provide lift and support the entire weight of the aircraft and its contents while in flight.

Flaps – Flaps are the movable sections of an airplane's wings that are closest to the fuselage. They move in the same direction on both wings at the same time, and enable the airplane to fly more slowly.

Ailerons – Ailerons are the outward movable sections of an airplane's wings. They move in opposite directions (if one goes up, the other goes down). They are used in making turns, and they control movement around the longitudinal axis (imagine a line through the airplane from the nose to the tail).

Rudder – The rudder is the movable vertical section of the tail that controls lateral (side-to-side) movement. When the rudder moves one direction, the aircraft nose moves the same direction, while the tail moves in the opposite direction.

Horizontal Stabilizer – The horizontal stabilizer is the horizontal surface at the rear of the fuselage designed to balance the airplane.

Elevator – The elevator is the movable horizontal section of the tail that causes the plane to move up and down. When the elevator moves one direction, the nose moves in the same direction.

Landing Gear – A landing gear is underneath the airplane and supports it while on the ground. A landing gear usually includes a wheel and tire.

Instrument Panel

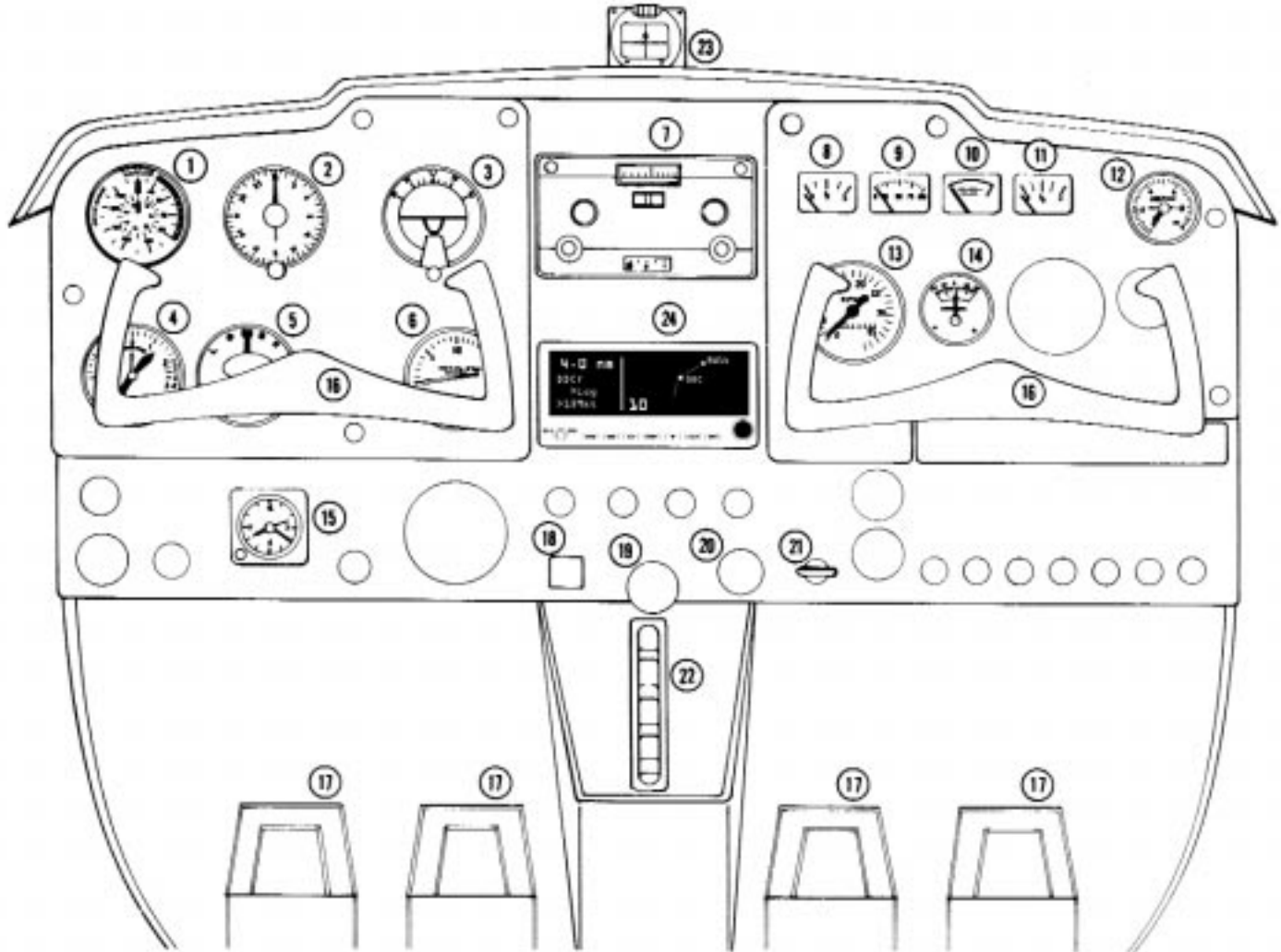

1. Airspeed Indicator
2. Gyroscopic compass
3. Artificial horizon
4. Altimeter
5. Turn-and-bank indicator
6. Vertical speed (rate-of-climb/descent indicator)
7. VHF navigation-communication radio
8. Fuel Gauge (left tank)
9. Oil pressure gauge
10. Oil temperature gauge
11. Fuel gauge (right tank)
12. Suction indicator (monitors vacuum pump, that activates flight instruments)
13. Tachometer (measures revolutions per minute of propeller)
14. Battery-generator indicator
15. Clock
16. Control wheel (dual)
17. Rudder pedals and brakes
18. Carburetor heat control
19. Throttle control
20. Fuel-air mixture control
21. Wing flaps control
22. Trim tab control
23. Magnetic compass
24. GPS Satellite Navigation Receiver

What Makes an Airplane Fly?

An airplane's movement through the air is affected by the *four forces of flight*:

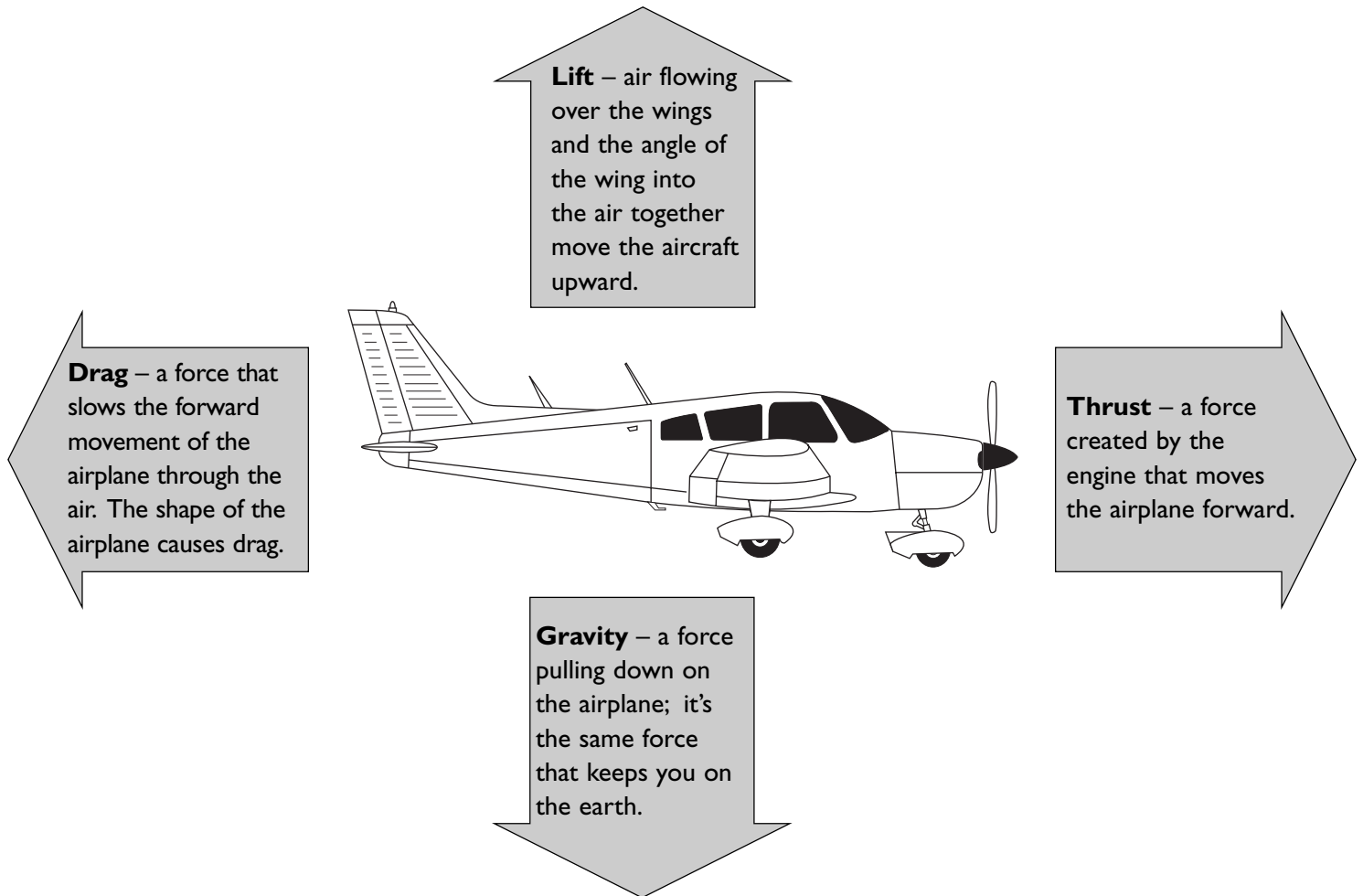

How is a Plane Controlled?

To control which way a plane turns and moves in the air and on the ground, a pilot moves parts on the wings and tail called control surfaces. **The control surfaces are the ailerons, rudder, and elevator.** You can see these in action by using folded paper gliders and balsa gliders.

EQUIPMENT: a sheet of paper and a paper clip

DESCRIPTION

Folded paper glider: Fold a piece of paper following the diagram A. You can use a paper clip to hold together the finished glider at the bottom. You can also use the paper clip for a balance on the airplane. Experiment with the glider, moving the clip up or back as needed to get it in balance.

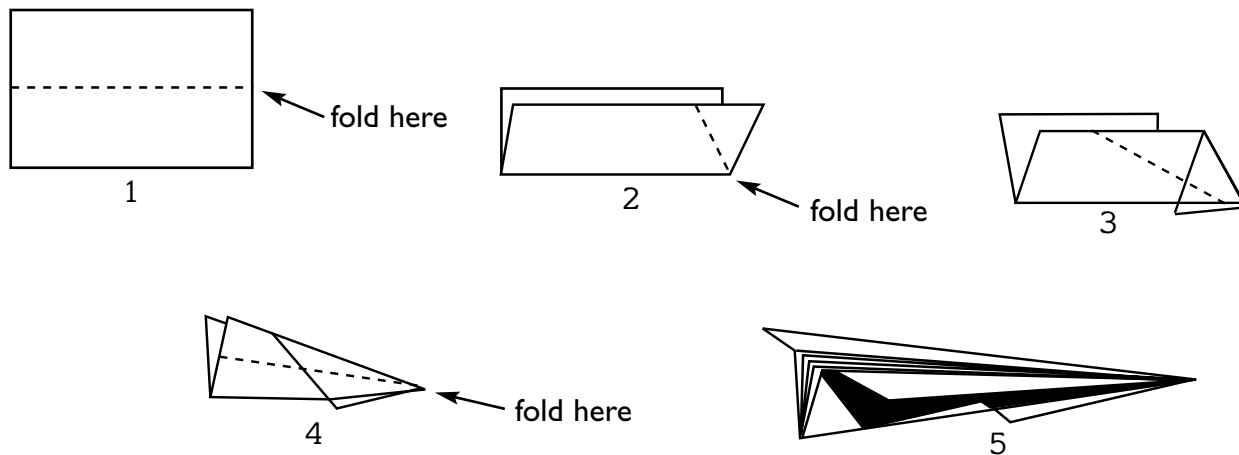

Diagram A

Control Surfaces: Real planes have movable parts inserted in the wings, in the vertical stabilizer, and in the horizontal stabilizer. These are called ailerons, rudder, and elevator. The pilot controls their position from the airplane cockpit. When he or she moves them into the airstream, they cause the plane to react to air pressure. By using them he can go to the right or left and also up and down.

Up and Down: Fold the back edges of the paper glider up, as in the diagram B. When you throw the glider, the tail should go down and the nose should point up. It may take some practice to get the controls set so the glider does what you want it to do.

When the pilot wants her plane to climb, she moves the airplane controls so that the **elevators** tilt up in the same way that you folded the back edges of the glider. The air hitting the **elevators** pushes the tail of the plane down, tilting the nose upward, so that the plane can climb.

Next, fold the back edges of the glider down. When you throw the glider, the tail should go up and the nose should go down. This same thing happens when the pilot tilts the **elevators** downward.

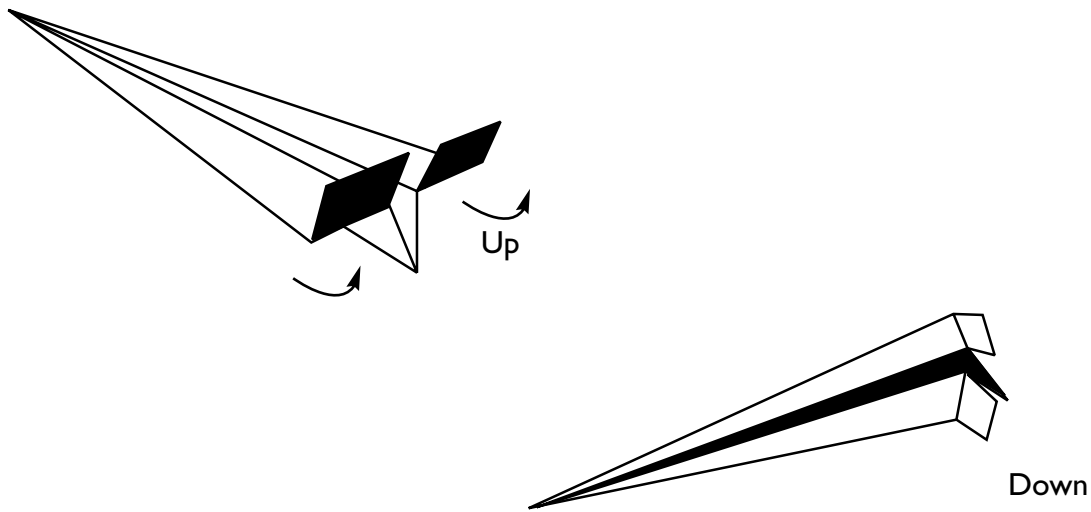

Diagram B

Right and Left: Turn the vertical fin on the glider a little to the right. This will make the glider fly toward the right (Diagram C). The pilot moves the airplane's **rudder** to the right for a right turn, but he must also bank his plane for the turn, the same as you would do if you were turning on a bicycle. (You would lean to the right for a right turn.)

The pilot tilts her plane to one side by using the **ailerons**. When one tilts up the other tilts down. To tilt the plane to the right, the pilot tilts the left **aileron** down so the left wing is pushed up. The right **aileron** is tilted up so the right wing will be pushed down. You can do the same thing with a paper glider. For a left turn, the pilot reverses the process described above.

Balsa glider: You can also use a balsa glider to see how **control surfaces** affect an airplane. Put the glider together and launch it a few times for practice. Make **ailerons**, **elevators**, and **rudder** from paper and glue them to the wings and stabilizers. Now practice bending these paper control surfaces until you can make the glider fly where you want it to.

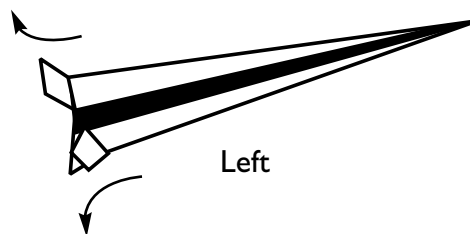

Diagram C

Wings

Experiments to demonstrate how aircraft wings work

The force that lifts an airplane and holds it up comes in part from the air that flows swiftly over and under its wings.

Bernoulli's principle states that an increase in the velocity of any fluid is always accompanied by a decrease in pressure. Air is a fluid. If you can cause the air to move rapidly on one side of a surface, the pressure on that side of the surface is less than that on its other side.

Bernoulli's principle works with an airplane wing. In motion, air hits the leading edge (front edge) of the wing. Some of the air moves under the wing, and some of it goes over the top. The air moving over the top of the curved wing must travel farther to reach the back of the wing, so it must travel faster than the air moving under the wing to reach the trailing edge (back edge) at the same time. Therefore the air pressure on top of the wing is less than that on the bottom of the wing.

You can see **Bernoulli's principle** in action in an experiment with two strips of paper.

EQUIPMENT: Strip of notebook paper or newspaper, about 2 inches wide and 10 inches long; a book; and paper clips

Make an airfoil (wing) by placing one end of the strip of paper between the pages of the book so that the other end hangs over the top of the book. Move the book swiftly through the air, or blow across the top of the strip of paper. It flutters upward. Hold the book in the breeze of an electric fan so the air blows over the top of the paper.

Take the strip of paper out of the book. Grasp one end of the paper and set it against your chin, just below your mouth. Hold it in place with your thumb and blow over the top of the strip. The paper rises. Try the same thing after you have fastened a paper clip on the end of the strip. See how many paper clips you can lift in this way.

Hold the strip of paper in your hands and run around the room. It doesn't matter whether you move the air over the strip of paper by blowing or whether you move the paper rapidly through the air - either way it rises.

Parts of an Airplane

Word Find

B C O P D Q Q W V F X V L H
 U A P V R I R K M L Z Y A M
 T S N H J O E F V A G A N H
 W G C O C K P I T P N Q D G
 F R M S P T S E P S Z O I I
 X L K R F U S E L A G E N J
 Y A I L E R O N S L U F G K
 E Z J N O W V E L Q E Y G J
 R U D D E R D R P A L R E D
 H I Q N T U O C B I A I A E
 G F A V E T O O C R B C R K
 B D X W A H N W D P X M F I
 Z Y C V I T S I H L L G J L
 M A E F G R R N Q A P O P M
 B L D E X A S G I N K L N J
 E C W Y U T Z S J E K L B K

Find these words:

- Propeller
- Cockpit
- Fuselage
- Ailerons
- Rudder
- Elevator
- Wings
- Airplane
- Flaps
- Landing Gear

Answer key:

Historical Aircraft Connect-the-Dot Puzzles

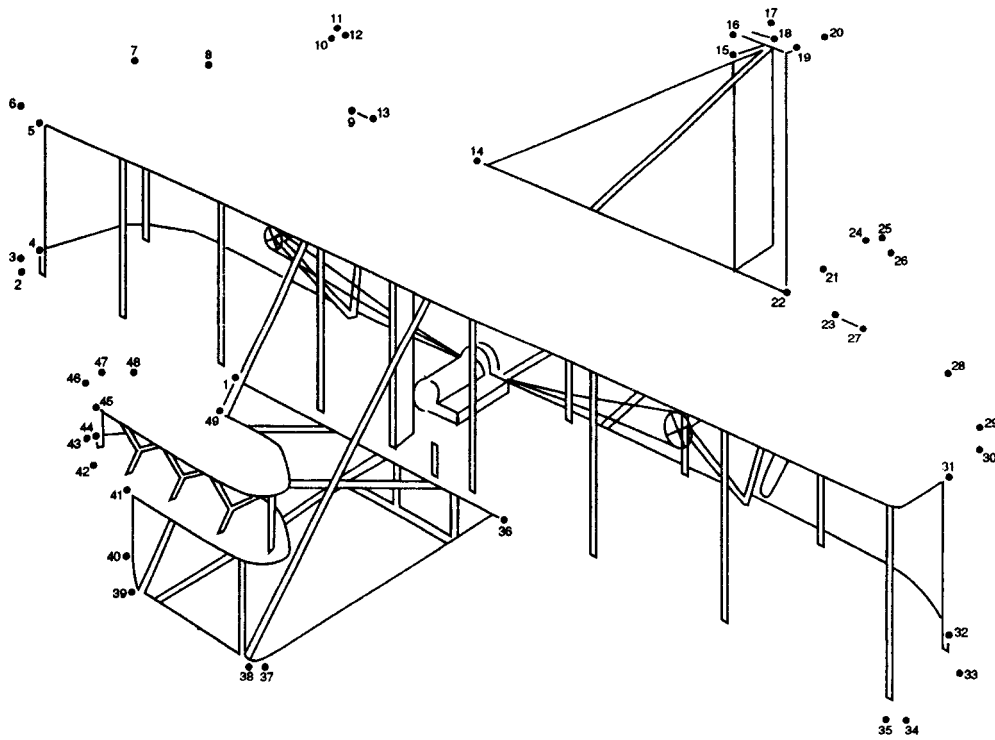

The Wright Flyer

The Wright Brothers' 1903 Flyer was a marvel of wood, wire and fabric. The Flyer's wings spanned 40' 4" and it was powered by a 12-horsepower, 140-pound engine. In flight, the pilot lay on the lower wing. The Wright Flyer flew just four times—a total of 98 seconds—all on December 17, 1903. Later that day, it was damaged by high winds and never again flown.

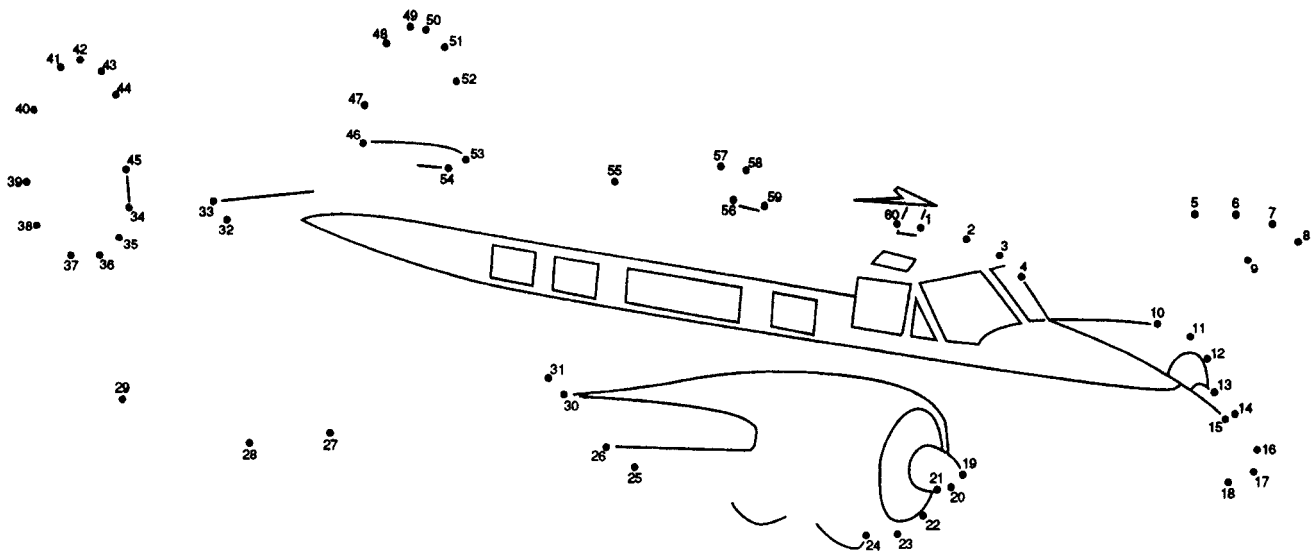

Beechcraft

The Beech 18 was first flown in January of 1937 and became a standard for business aviation aircraft. The original Beech 18s had a cruise speed of 196 miles per hour and a range of just over 1,000 miles. It cost about \$30,000. The last Beech 18 rolled out of the factory on November 26, 1969. It was a Beechcraft Super H18 model, had a cruise speed of 220 miles per hour, a range of just over 1,500 miles, and cost around \$180,000.

Some Web sites, books, and videos to try

Web sites

AOPA assumes no responsibility for availability or content of items listed.

www.aopa.org	Aircraft Owners and Pilots Association – thousands of pages of information from the world’s largest civil aviation organization
www.aopaflighttraining.org	AOPA Flight Training magazine –for new and student pilots
www.nasa.gov/kids.html	National Aeronautics and Space Administration’s pages and links for young people
www.avkids.com	National Business Aviation Association “AvKids” program
www.faa.gov/education	Federal Aviation Administration: “designed to help bring the excitement and opportunities of aviation to young minds everywhere.”
www.aviationeducation.org	National Coalition for Aviation Education – links to hundreds of free materials
http://education.dot.gov/	U.S. Department of Transportation (DOT) - information about careers in transportation

Books

Aviation and Space Science Projects	Dr. Ben Millsbaugh	McGraw-Hill, 1992	ISBN 0-8306-2156-3
Flights of Imagination	Wayne Hosking	National Science Teachers Association	ISBN 0-87355-067-6
Skybusters –Sixteen Fantastic Cardboard Aircraft to Make and Fly	Campbell Morris	Scholastic, 1990	ISBN 0-590-22285-6
The Usborne Book of Cutaway Planes	Clive Gifford	Usborne Publishing, 1995	ISBN 07460 17197
What’s a Piper Cub?	Jim Wheaton	Humpty Bump Publishing, 1997	ISBN 0-9658514-0-0

Videos

Source	Phone	Title/ Run Time	Audience	Cost
GAMA 1400 K St NW, Suite 801 Washington, DC 20005	202-393-1500	Take Off for Opportunity 11 minutes	Middle & High School	\$12.00
King Schools, Inc. 3840 Calle Fortunada San Diego, CA 92123	800-854-1001	Let’s Go Flying 60 minutes	Middle & High School	\$29.00
Meriden House, LTD Video Publishing PO Box 281 Meriden, NH 03770	800-260-3434	Airplanes and Airports 15 minutes	Ages 3 – 5	\$39.95
		Let’s Go Flying, Kids 30 minutes	Ages 5 – 7	\$19.95
Sporty’s Pilot Shop Wright Bros. Collection Clermont County Airport Batavia, OH 45103	800-543-8633	Cleared to Land <i>Item – M453W • 60 minutes</i>	Elementary	\$12.95
		Where Do Planes Sleep? <i>Item – M745W • 30 minutes</i>	Ages 2 - 8	\$14.95

High Flight

Oh! I have slipped the surly bonds of earth
And danced the skies on laughter-silvered wings;
Sunward I've climbed, and joined the tumbling mirth
Of sun-split clouds - and done a hundred things
You have not dreamed of -
wheeled and soared and swung
High in the sunlit silence. Hov'ring there
I've chased the shouting wind along, and flung
My eager craft through footless halls of air.
Up, up the long delirious, burning blue,
I've topped the windswept heights with easy grace
Where never lark, or even eagle flew -
And, while with silent lifting mind I've trod
The high unsurpassed sanctity of space,
Put out my hand and touched the face of God.

*Pilot Officer John Gillespie Magee
No 412 Squadron, RCAF*



AIRCRAFT OWNERS AND PILOTS ASSOCIATION

421 Aviation Way • Frederick, MD 21701 • www.aopa.org

- 12 -